

Étagère double coulissante XL

Designed by Sebastian Bergne Ltd.

*Sliding Double Shelf



The Sliding Shelf designed by Sebastian Bergne is very clever. Designed from 2 aluminum trays that slide in one another, the shelf could be expanded by a simple slip while remaining attached to the wall. On this XL version, the Sliding Shelf is deeper and higher to welcome 21 x 29.7 cm (A4) size books.

The fixed tray and the sliding tray can be independently selected in Mat and Mat Fine Texture finishes from our ESSENTIELS and TENDANCES color charts for a personalized Mix & Match!

- Expanded from 64 up to 96 cm
- Welcome A4 books
- Available in ESSENTIELS and TENDANCES color charts (but Brut Vernis)

TOLIX®

Étagère double coulissante XL

Designed by Sebastian Bergne Ltd.

Product specifications

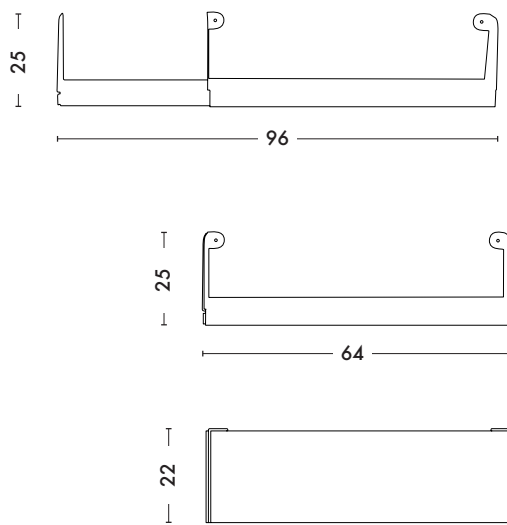

Dimensions

LENGTH	64/96 cm
DEPTH	22 cm
HEIGHT	25 cm

Designer	Sebastian Bergne Ltd.
Use	TOLIX® maison
Material	Aluminum
Finishes / Colors	Available in the colors and finishes of the color charts ESSENTIELS and TENDANCES
Max load capacity	15 kg (fixed part) 5 kg (Sliding part)
Weight	2.7 kg



Tolix® Essentiels

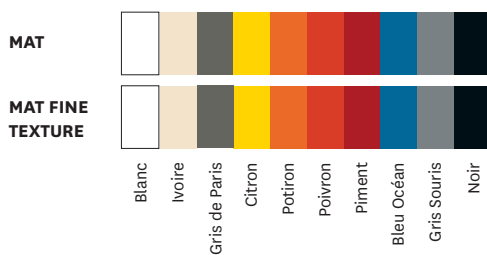

Tolix® Tendances

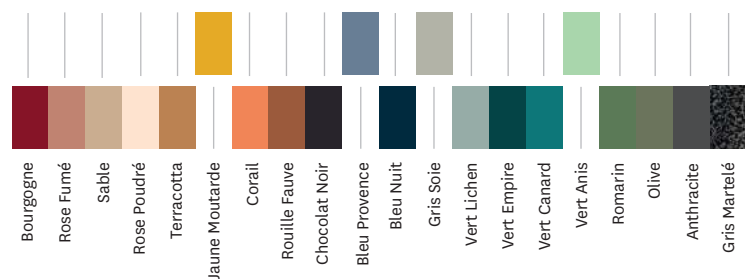

TOLIX®