

CERCLE & TRAIT

DESIGNED BY POOL

D'une apparente légèreté, les formes de *Cercle & trait* se frottent et se tiennent dans un jeu d'équilibre savamment dosé. Une suspension graphique déclinée en différentes finitions qui ne tient qu'à un fil.



As light as it looks, the forms of *Cercle & trait* rub together and hold together in a cleverly measured balance. A graphic pendant, available in different finishes, is just held by one small wire.



Cercle & trait XL SG

'The Conran Loft' © Charlotte Taylor x Hannes

Finitions Finishes	 Laiton satiné	 Graphite satiné	 Nickel satiné	 Cuivre satiné
	SB Satin brass	SG Satin graphite	SN Satin nickel	SC Satin copper

Matériaux Material	Laiton massif	Diffuseur en polycarbonate blanc	Câble textile noir (longueur ≈ 1 m)
	Solid Brass	White polycarbonate diffuser	Black textile cable (length ≈ 39.4")

Source Lamping	Suspension – Pendant XL	Alim. 24 V intégrée dans le pavillon LED 1400 lm 2700°K Int. power supply 24V included in canopy	Variable (phase cut) Dimmable (phase cut)	
	Suspension – Pendant XS	Alim. 24 V intégrée dans le pavillon LED 900 lm 2700°K Int. power supply 24V included in canopy	Variable (phase cut) Dimmable (phase cut)	

Designer POOL

Cercle & trait XL

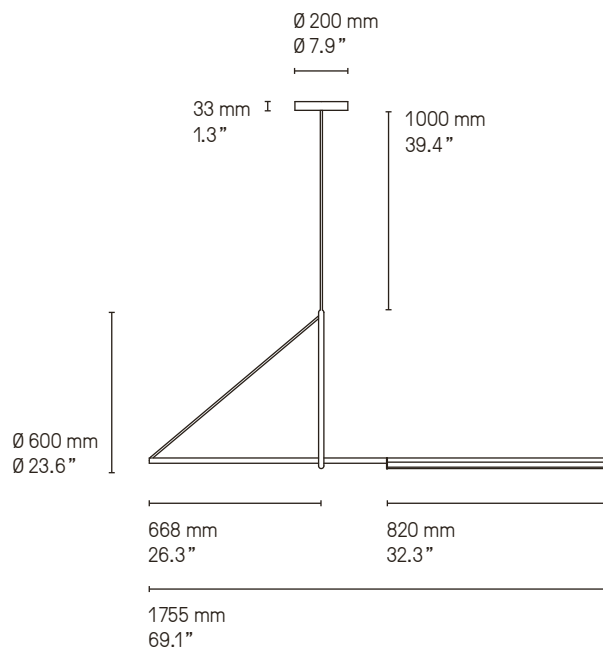
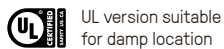

Cercle & trait XS

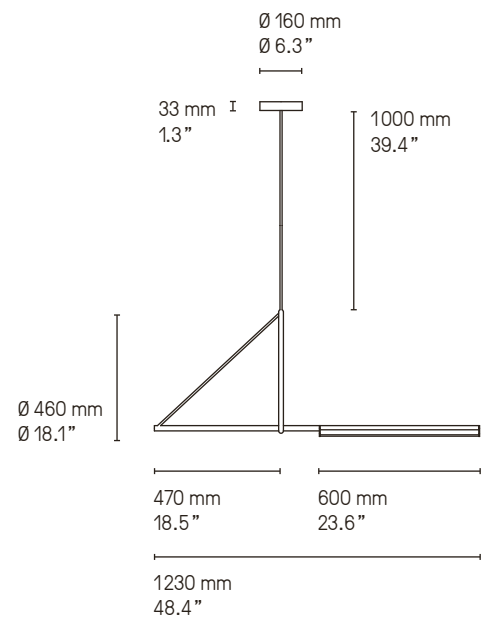

Cercle & trait est un projet sur le mouvement des formes et l'équilibre qui s'entremêlent.

Ce luminaire comme un mobile crée une lumière en mouvement.

Cercle & trait is a design between movement of forms and balance that intertwine.

Like a mobile this luminaire creates a light in motion.



Cercle & trait XL SG + XL SB

© DesignTwoGroup

NUANCIER - FINISH OPTIONS



LAITON - BRASS

- | | |
|-------------------------------------|---|
| ① Laiton satiné
SB Satin brass | ② Graphite satiné
SG Satin graphite |
| ③ Nickel satiné
SN Satin nickel | ④ Cuivre satiné
SC Satin copper |
| ⑤ Laiton poli
PB Polished brass | ⑥ Graphite poli
PG Polished graphite |
| ⑦ Nickel poli
PN Polished nickel | ⑧ Cuivre poli
PC Polished copper |

ABAT-JOURS - LAMPSHADES



Drop Paper® 100



Drop Paper® 101



Drop Paper® 103



Chinette blanche
White chinette



Chinette noire
Black chinette



Duke
Duke

CÂBLES - CABLES

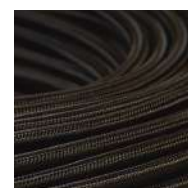

Tissu noir
Black textile



Tissu or
Gold textile

VERRERIE - GLASS



Opale
Opal



Opale et écaille
Opal and patterned

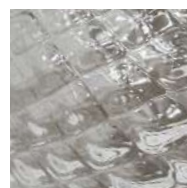

Claire et écaille
Clear and patterned



© Yannick Labrousse

CVL LUMINAIRES

79 ROUTE DE LA CHEVALLERIE - 49770 LONGUENÉE-EN-ANJOU - FRANCE

TEL. +33 (0) 2 41 32 67 54

EMAIL : CONTACT@CVL-LUMINAIRES.FR

WWW.CVL-LUMINAIRES.FR

Brand identity & art direction: [POOL](#) Layout & production supervision: [deuxpointdeux](#)
Texts: [Valérie Marion](#) Translation: [CVL](#) Photos: [Garnier Studios](#) except when mentioned otherwise 3D: [CVL](#) except when mentioned otherwise

Make sure to download our latest catalogue [here](#)