

# Vestiaire B1 perforé\*

*Designed by Xavier Pauchard, revisited by Chantal Andriot*



\*Perforated B1 Locker

***TOLIX® has renewed its Lockers with Perforated Lockers. These models bring to mind the memory of the industrial world's raw esthetics, while adding modern and refined details. The perforated steel doors subtly hint at the contents placed inside. Raw steel is offset by the elegant and natural oak handle. The product comes with two height-adjustable shelves, and a set of two more shelves (sold separately) can also be added. Perforated Lockers exist in one- and two-door tall versions (Perforated B1 Tall, Perforated B2 Tall), and in low versions with one, two or three doors (Perforated B1 Low, Perforated B2 Low and Perforated B3 Low). Order any of the Lockers in any of the colors and finishes in the ESSENTIELS and TENDANCES color charts.***

- Historical piece of the TOLIX® collection, in a perforated version
- Available in the color charts ESSENTIELS and TENDANCES
- Contains 1 short shelf with wardrobe, adjustable
- Possibility of buying a pair of 2 or 4 extra shelves

**TOLIX®**

# Vestiaire B1 perforé

Designed by Xavier Pauchard, revisited by Chantal Andriot

## Product specifications

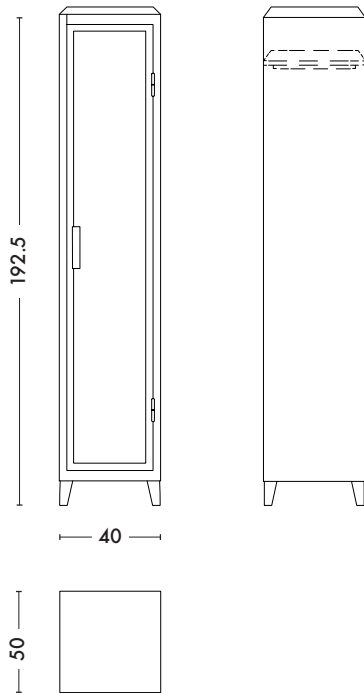

<b>Designer</b>	Xavier Pauchard Revisited by Chantal Andriot
<b>Use</b>	<b>TOLIX®</b> maison
<b>Material</b>	Steel and Oak
<b>Finishes / Colors</b>	Available in the colors and finishes of the color charts ESSENTIELS and TENDANCES
<b>Weight</b>	30.0 kg
	One shelf included. Extra set of 2 or 4 shelves are available



### Dimensions

LENGTH	40 cm
DEPTH	50 cm
HEIGHT	192.5 cm

### Tolix® Essentiels

<b>MAT</b>	
<b>MAT FINE TEXTURE</b>	

### Tolix® Tendances

--

**TOLIX®**